



SOLUTIONS FOR A CLEANER FUTURE

COLLEC'THOR

fixed waste collector

Join the community
#iamasearialcleaner
searial-cleaners.com



COLLEC'THOR

TRASH SKIMMER

FIXED QUAY

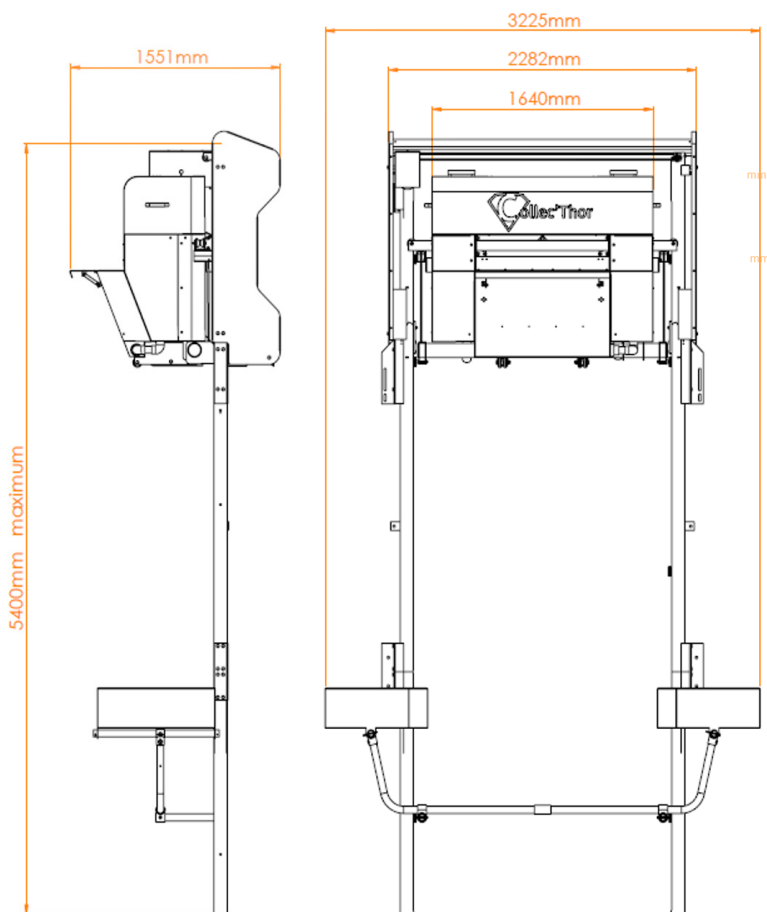

TECHNICAL SPECIFICATIONS

Pump power	750 Watts
Pump flow	32 000 l/h
Tank collection capacity	320 liters
Material	Aluminium 5754
Self-floating	Adapts to changing water levels

REQUIRED SITE CONDITIONS

Install on fixed quays pontoons
Maximum wave height in the marina : 0,3 m / 11,8 in
There is a minimum 1,5 m / 59 in of draught on the lowest astronomical tide
Freeboard range : 200 to 3000 mm / 7,9 to 118 in
Maximum water current speed : 1,5 knots
Weight of the set with the lifting structure: 260Kg, / 529 lbs

ACCESSORIES & OPTIONS

Oil pads
Fixed quay
Mobile pontoon

CONTACT

Email : contact@searial-cleaners.com