



SOLUTIONS FOR A CLEANER FUTURE

COLLEC'THOR

fixed waste collector

Join the community
#iamasearialcleaner
searial-cleaners.com



COLLEC'THOR

FIXED-WASTE COLLECTOR



1381 mm

2392 mm

1640 mm

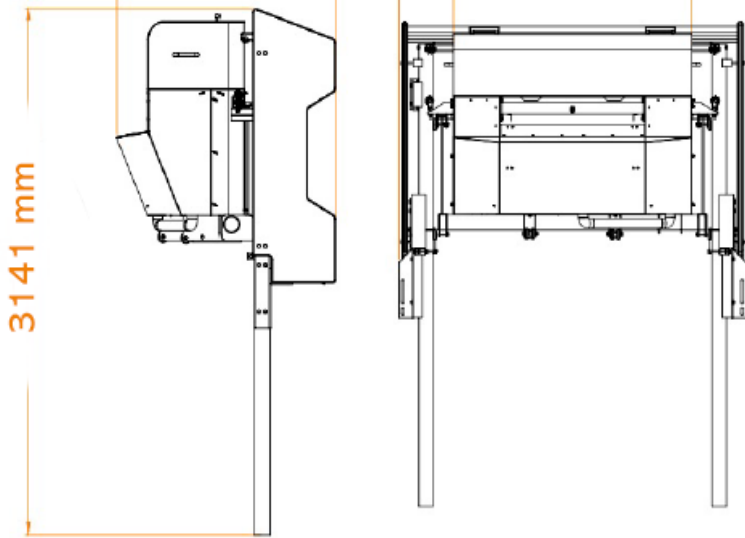

TECHNICAL SPECIFICATIONS

Pump power	750 Watts
Pump flow	32 000 l/h
Tank collection capacity	320 litres
Material	Brackets and tank in Aluminium 5754

MANDATORY CONDITIONS INSTALLATION AND USE

Install on floating pontoons
Maximum permissible chop height : 0,30 m
Maximum permissible wave height : 0,30 m
Minimum depth at low tide : 1,5 m
Freeboard range : between 320 and 820 mm
Maximum current speed : 1,5 knots
Weight of the set with the lifting structure: 240Kg / 529 lbs

ACCESSORIES & OPTIONS

Oil pads
Fixed quay
Mobile pontoon

CONTACT

contact@searial-cleaners.com

www.searial-cleaners.com